

930-THR(-DS)

PCB connector for THR
Screw connection

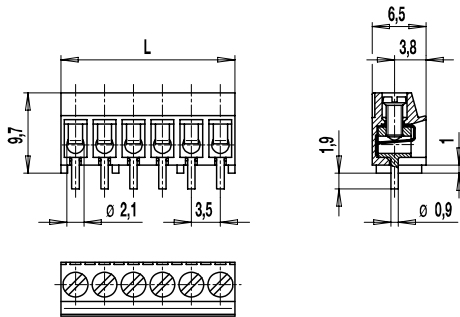

PCB Layout

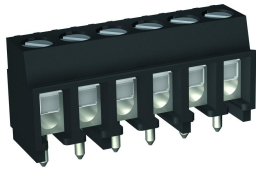
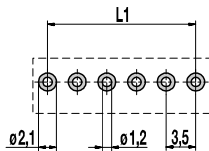

$L1 = (\text{No. of poles} - 1) \times \text{pitch}$
Solder paste thickness: 0,15 - 0,2 mm
Solder pad diameter: \varnothing 2,1 mm

This product based on our established 930 series have been designed for the soldering process in Through-Hole-Reflow technology.

The soldering paste is applied to the plated through holes and the pins are placed in the circuit board and soldered by a reflow oven.

The terminal mouldings are made of heat-resistant material. The stand-offs on the base ensures there is enough room for the soldering paste and facilitates good heat circulation for optimum soldering and enables the soldering joint to be visually inspected.

The solder pin projects very slightly with a circuit board thickness of 1,6 mm and creates a solder point on both sides and thus guarantees a secure mounting. The position of the solder pins enables an equally minimal allocation area on the circuit board as with wave soldering.

Part Numbers

No. of poles	930-THR	930-THR-DS	Length	PU
2	10.879.002	20.879.002	7,40	250
3	10.879.003	20.879.003	10,90	250
4	10.879.004	20.879.004	14,40	250
5	10.879.005	20.879.005	17,90	200
6	10.879.006	20.879.006	21,40	200
7	10.879.007	20.879.007	24,90	100
8	10.879.008	20.879.008	28,40	100
9	10.879.009	20.879.009	31,90	100
10	10.879.010	20.879.010	35,40	100
11	10.879.011	20.879.011	38,90	100
12	10.879.012	20.879.012	42,40	100
15	10.879.015	20.879.015	52,90	100

General Information

Pitch	3,5 mm
No. of poles	2 - 12, 15

Technical Data

Clamping Range	<i>solid / flexible / AWG</i>		
<i>without wire protector</i>	0,75 - 1,5 mm ² / 0,75 - 1,5 mm ² / 18 - 16 AWG		
<i>with wire protector</i>	0,34 - 1,5 mm ² / 0,34 - 1 mm ² / 22 - 16 AWG		
Rated Cross Section	1 mm ²		
Wire Stripping Length	5 mm \pm 0,5 mm		
Overvoltage Category	III	III	II
Pollution Severity Level	3	2	2
Rated Voltage	160 V	160 V	320 V
Rated Impulse Voltage	2,5 kV	2,5 kV	2,5 kV
Rated Insulation Voltage	130 V acc. to EN 60998-1		
Rated Current	13,5 A		
Soldering process	Wave solder & reflow solder		
Hole in PCB	\varnothing 1,2 mm		
PCB thickness	Wave solder max. 1,6 mm; reflow solder 0,8-1,6 mm		
Torque	0,2 Nm		

Material

Moulding	PA HT, black, V-0
Comparative Tracking Index	CTI \geq 600
Insulating Group	I
Temperature Range	-40°C up to 120°C; reflow solder temperature peak max. 255°C acc. to DIN EN 61760-1
Terminal body	Tin plated brass
Screw	M2; zinc plated steel, blue passivated
Solder pin	\varnothing 0,9 mm; tin plated brass
Wire protector	German silver

Approvals

	Current [A]	Voltage [V]	Group	AWG	[Nm]
	10	300	B	26 - 16	0,23
	10	300	B	26 - 16	0,2

Options / Accessories

- Special marking according to drawing
- Self-adhesive marking strip BST-3,50 [1]
- Other solder pin lengths on request
- Large conductor space with terminal body 938 on request

Part Numbers: Tape-on-Reel

No. of poles	930-THR	930-THR-DS	Tape Width	Tape Height	PU
3		20.879.003.A00	32 mm	13 mm	500
6		20.879.006.A00	56 mm	13 mm	500
12		20.879.012.A00	56 mm	13 mm	500

further number of poles on request

[1] To be fitted after reflow soldering process