

952(-DS)

PCB connector
Screw connection

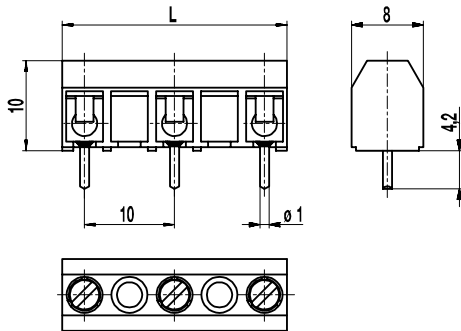
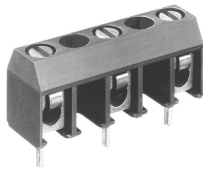

PCB connector 952 with a pitch of 10 mm is available in 2- to 16-pole design and is a very space saving PCB connector.

Wire protection in DS-design reliably prevents damage to stranded wires by the screw.

The screws are secured against self-loosening.

Part Numbers

No. of poles	952	952-DS	Length	PU
2	12.871.053	22.871.053	15,00	250
3	12.871.055	22.871.055	25,00	100
4	12.871.001	22.871.001	35,00	100
5	12.871.009	22.871.009	45,00	100
6	12.871.011	22.871.011	55,00	100
7	12.871.063	22.871.063	65,00	100
8	12.871.065	22.871.065	75,00	100
9	12.871.067	22.871.067	85,00	100
10	12.871.069	22.871.069	95,00	100
11	12.871.071	22.871.071	105,00	100
12	12.871.073	22.871.073	115,00	100
13	12.871.075	22.871.075	125,00	100
14	12.871.077	22.871.077	135,00	100
15	12.871.079	22.871.079	145,00	100
16	12.871.061	22.871.061	155,00	100

General Information

Pitch	10 mm
No. of poles	2 - 16



Technical Data

Clamping Range	<i>solid / flexible / AWG</i>		
<i>without wire protector</i>	0,75 - 4 mm ² / 0,75 - 2,5 mm ² / 18 - 12 AWG		
<i>with wire protector</i>	0,34 - 2,5 mm ² / 0,34 - 2,5 mm ² / 22 - 14 AWG		
Rated Cross Section	1,5 mm ²		
Wire Stripping Length	6 mm ± 0,5 mm		
Overvoltage Category	III	III	II
Pollution Severity Level	3	2	2
Rated Voltage	630 V (500 V)	630 V	1000 V
Rated Impulse Voltage	6 kV	6 kV	6 kV
Rated Insulation Voltage	750 V acc. to EN 60998-1		
Rated Current	17,5 A		
Hole in PCB	ø 1,3 mm		
Torque	0,4 Nm		
Other specifications	Rated voltage in brackets applies to 5-16-pole connectors, "no-flame" according to glow wire test applies to 2-4-pole connectors.		

Material

Moulding	PA, grey, V-0
Comparative Tracking Index	2-4 poles: CTI ≥ 600; 5-16 poles: CTI 400
Insulating Group	2-4 poles: I; 5-16 poles: II
Temperature Range	-40°C up to 100°C
Terminal body	Tin plated brass
Screw	M2,6; zinc plated steel, blue passivated
Solder pin	ø 1 mm; tin plated copper
Wire protector	Tin plated tin bronze

Approvals

	Current [A]	Voltage [V]	Group	AWG	[Nm]
	15	300	B	26 - 14	0,4
	10	300	D	26 - 14	0,4
	15	300	B	26 - 14	0,4
	10	300	D, E	26 - 14	0,4

Options / Accessories

- Consecutive numbering
- Special marking according to drawing
- Self-adhesive marking strip BST-10,00
- Longer solder pins up to 75 mm